



Construction

Close-coupled centrifugal pumps with open impeller. The built-in backflow preventer avoids reverse siphoning when the pump is stopped and assures automatic re-priming at the next start. The pump re-primed itself even if partially filled with liquid and with completely empty suction pipe.

Applications

For clean or slightly dirty water, also with solids up to 10 mm grain size for A 40, A 50 and 15 mm for A 65, A 80. For draining a basin or a sump. For irrigation. For civil and industrial applications.

Operating conditions

Liquid temperature from -10 °C to +90 °C. Room temperature up to 40 °C. Maximum permissible working pressure up to 6 bar (10 bar for A 80-170). Continuous duty.

Motor

2-pole induction motor, 50 Hz (n = 2900 rpm).
A : three-phase 230/400 V ± 10%.
AM: single-phase 230 V ± 10%, with thermal protector. Capacitor inside the terminal box.
 Insulation class F.
 Protection IP 54
 Constructed in accordance with IEC 60034.

Special features on request

Other voltages.
 Frequency 60 Hz (as per 60 Hz data sheet).
 Protection IP 55.
 Special mechanical seal.
 Higher or lower liquid or ambient temperatures.
 Explosion proof construction in accordance with Directive 94/9 EEC (ATEX).
 Construction with bearing bracket.

Materials

Components	A	B-A
Pump casing Suction flange Inspection cover (for A 65, A 80) Lantern bracket Impeller	Cast iron GJL 200 EN 1561	Bronze G-Cu Sn 10 EN 1982
Shaft	Chrome-nickel steel 1.4305 EN 10088 (AISI 303) Chrome steel 1.4104 EN 10088 (AISI 430) for A 65-150AE, BE	Cr-Ni-Mo steel 1.4401 EN 10088 (AISI 316)
Mechanical seal	Carbon - Ceramic - NBR	

Coverage chart n ≈ 2900 rpm

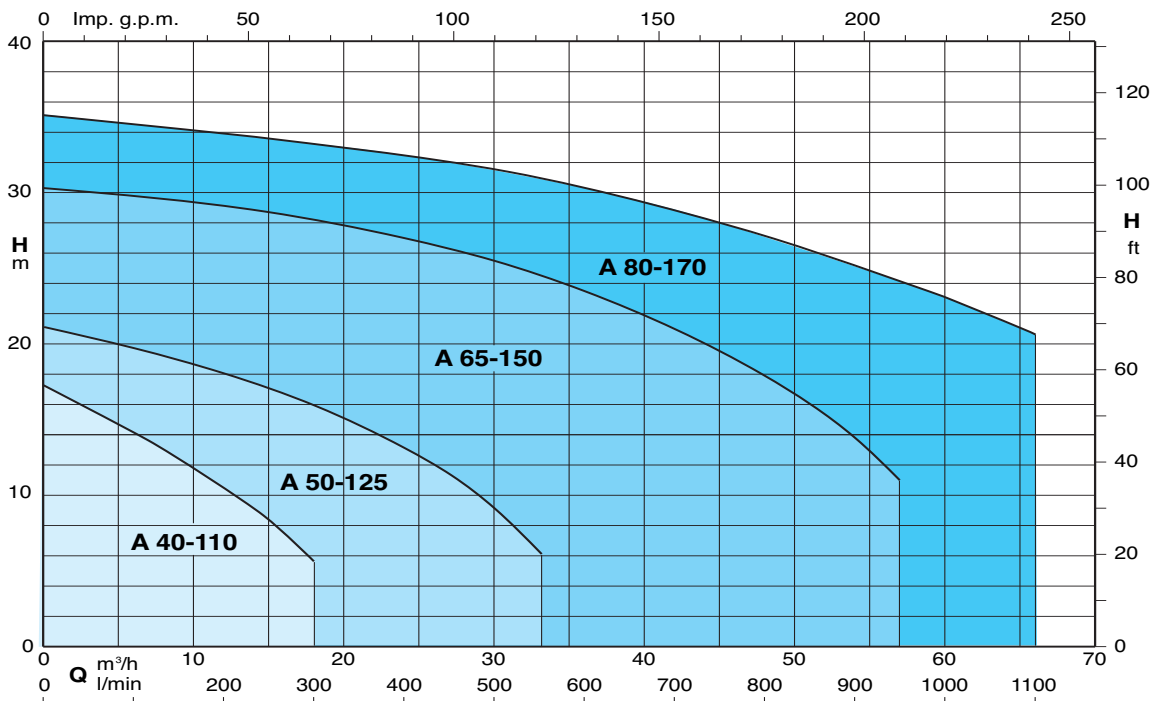



Self-priming Capability

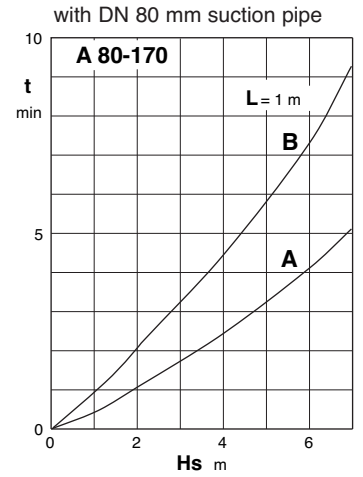
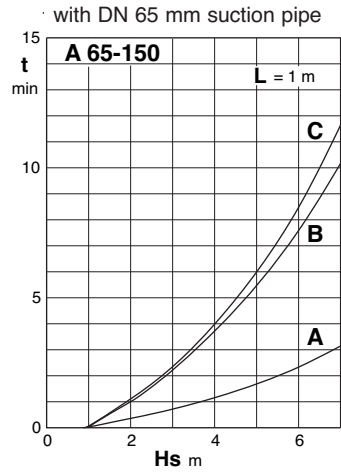
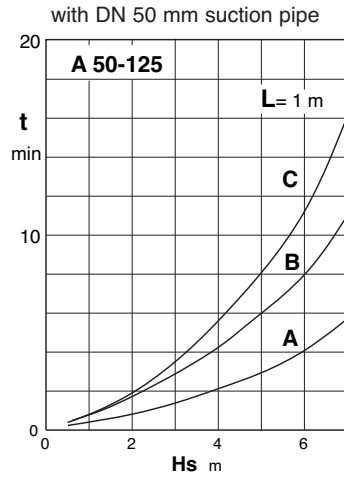
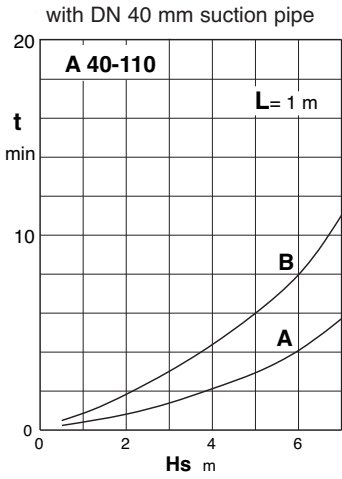

Hs (m) Suction lift.

L (m) Horizontal length of suction pipe above the water level.

t (min) Self-priming time.

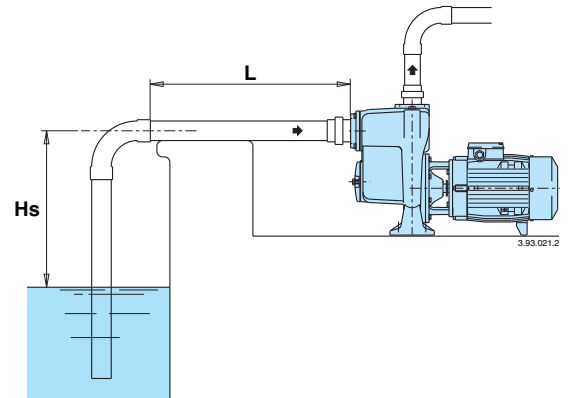



Characteristic curves $n \approx 2900$ rpm

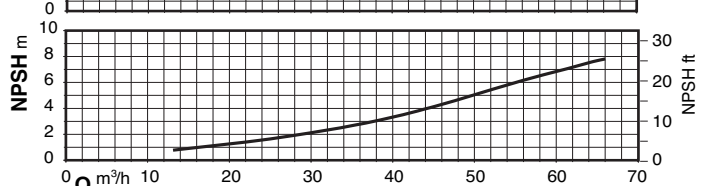
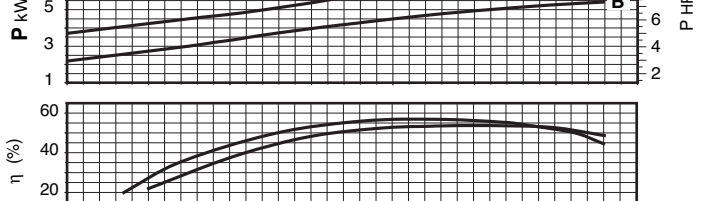
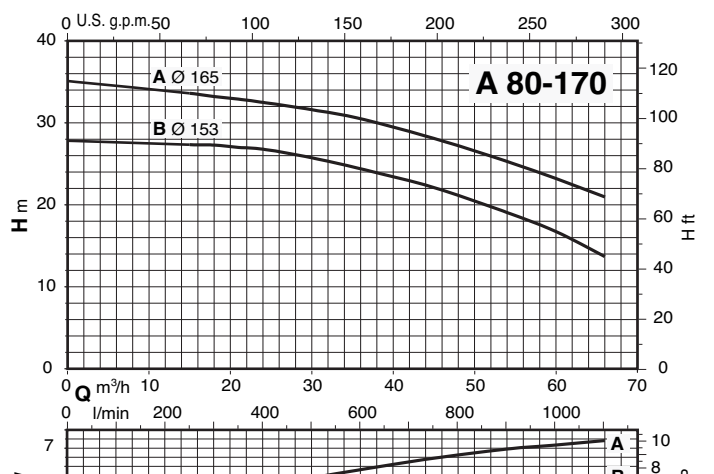
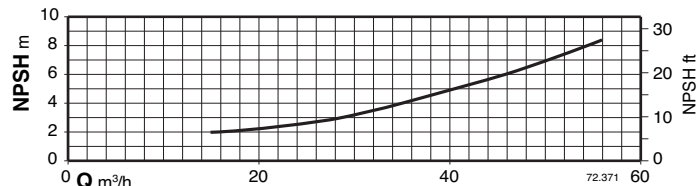
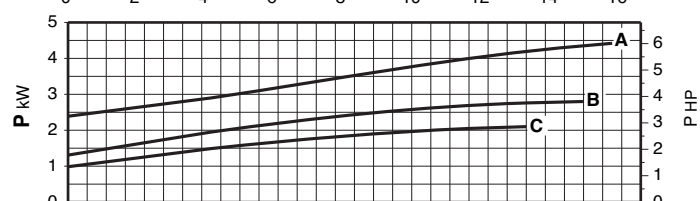
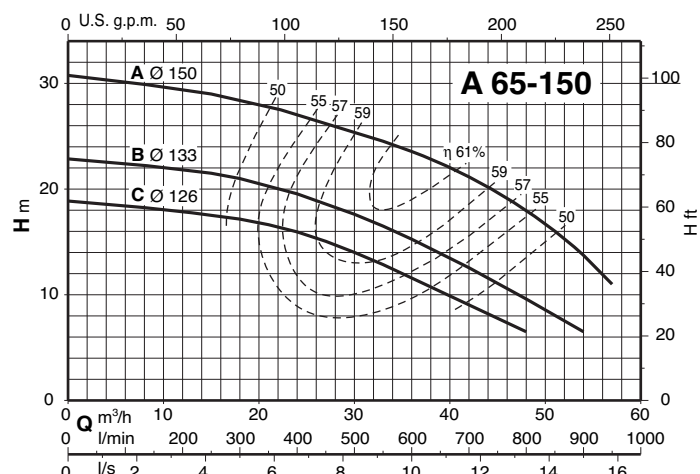
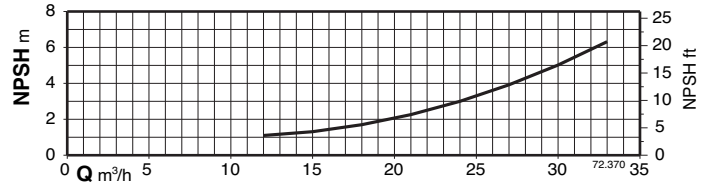
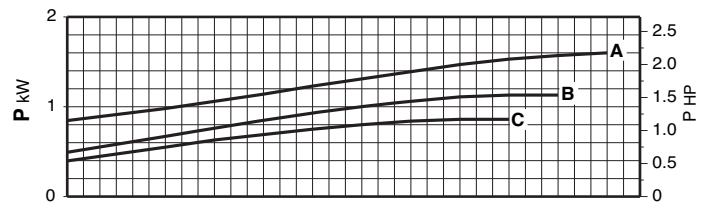
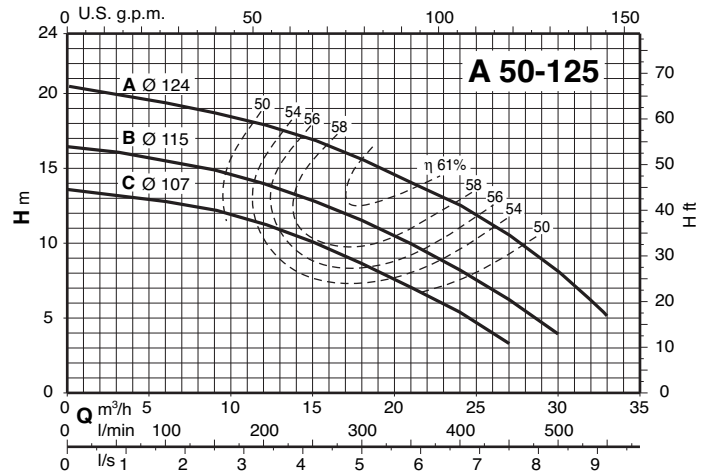
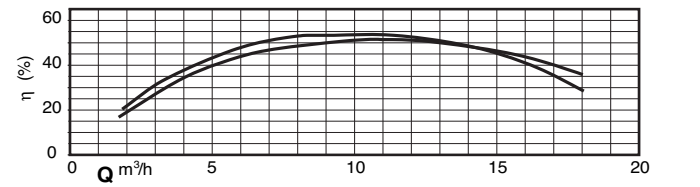
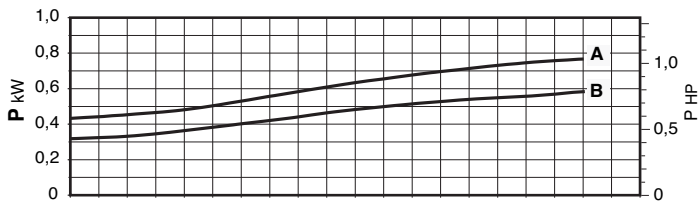
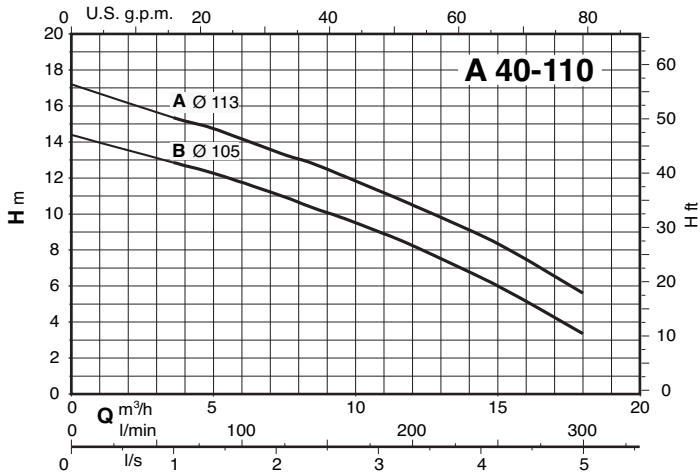



Dimensions and weights

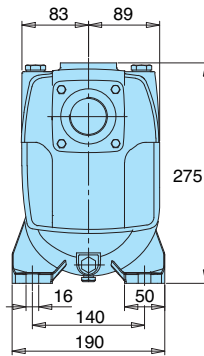
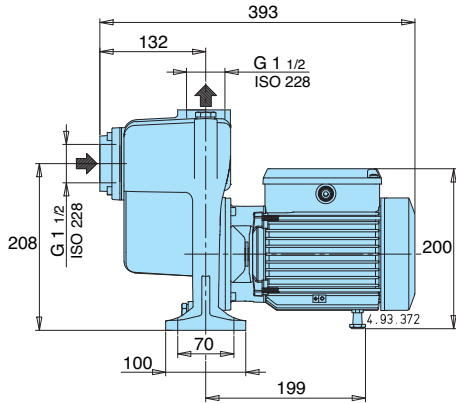

	kg
A 40-110A	19,8
AM 40-110A	20,8
A 40-110B	18,9
AM 40-110B	19,8

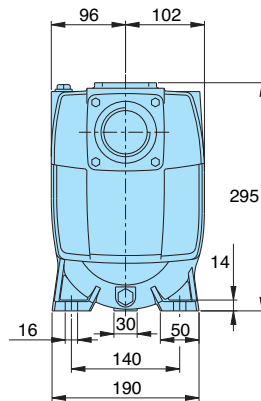
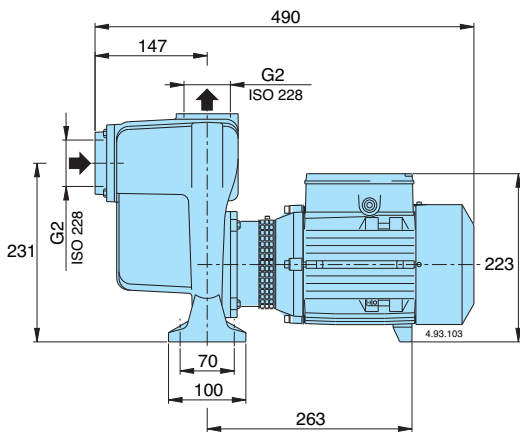

	kg
A 50-125AE	29,9
AM 50-125AE	31
A 50-125BE	28
AM 50-125BE	29,1
A 50-125CE	26,9
AM 50-125CE	27,8

B-A 50-125AE	33,6
B-AM 50-125AE	33,6
B-A 50-125BE	31
B-AM 50-125BE	32,6
B-A 50-125CE	29,6
B-AM 50-125CE	30,6

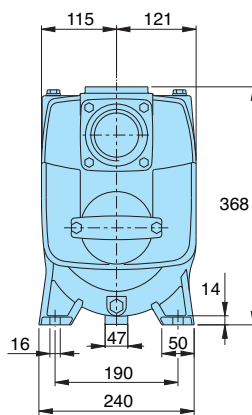
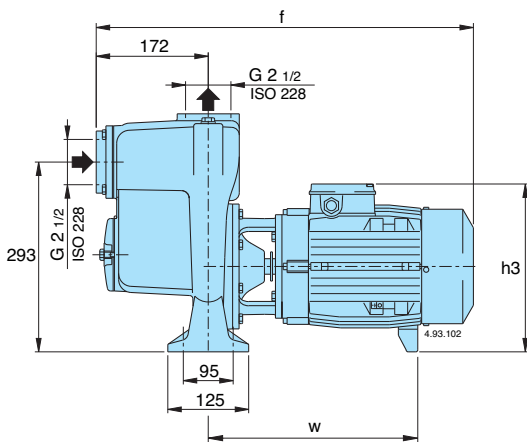

TYPE	mm			kg
	f	h3	w	
A 65-150CE	543	260	279	46
B-A 65-150CE				47,5
A 65-150BE	595	260	324	54
B-A 65-150BE				55,5
A 65-150AE	595	260	324	58
B-A 65-150AE				59,5

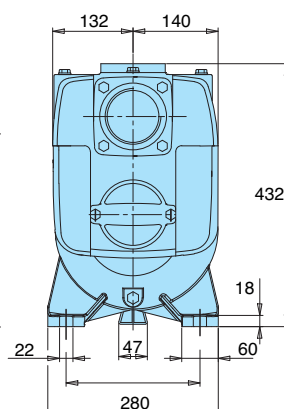
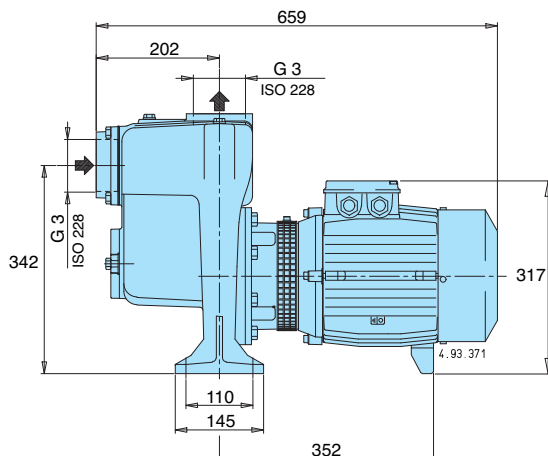

	kg
A 80-170A	85,3
A 80-170B	79,3